

# Mountain Promise

Vol. 7, No. 2

The Newsletter of the Brushy Fork Institute

Fall/Winter, 1996/97

## *A word on wood*

### The economy of secondary wood products

*Editor's note: As the world is looking to the southern United States for wood materials and products, secondary wood industries are an economic alternative for many states. Opinions about the development and sustainability of forest industries are as varied as the species of trees that cover the hillsides of Central Appalachia. In the articles below, wood products professionals discuss current trends in the region.*

#### *In Kentucky*

#### Developing people and technology

by Albert Spencer, Secondary Wood Industry Specialist at the Eastern Kentucky Technology Center, Eastern Kentucky University

Wood has always been important to the economy of Kentucky, but the potential of our forest resources has never been fully realized. The supremacy of coal in years past took away most of the incentive to develop wood products manufacturing.

On the other hand, secondary wood manufacturing in surrounding states did grow. These states looked to Kentucky as a source of hardwood

*continued on page 2*

#### *In West Virginia*

#### Adding value piece by piece

from an interview with Joel Stopha, Wood Products Marketing Specialist at the Appalachian Hardwood Center, West Virginia University

The wood products industry is growing in West Virginia. According to a survey by the *Charleston Gazette*, wood processing and furniture jobs are up by about 3,000 over the number in 1980. Not everyone is happy with the growth as some people worry about exploitation of the state's resources and labor, but Joel Stopha of the Appalachian Hardwood Center sees promise in

*continued on page 3*

#### *In Virginia and Tennessee*

#### Updating old techniques

condensed from material by Anthony Flaccavento, Executive Director of the Clinch Powell Sustainable Development Initiative

There is good news and bad news from the forests of Appalachian Virginia and Tennessee. The good news is that the forests are abundant, and that at present, trees are being regenerated faster than they're being cut. Jobs in logging, sawmilling and wood manufacturing are growing to the point that many economic development officials are touting wood products as the region's future.

*continued on page 4*

topic this issue

### Forestry and Secondary Wood Products

Teamwork for Tomorrow dates set

*page 5*

The state of our forests

*page 8*

Crafting wood in Southwest Virginia

*page 10*

toolbox: Building a flip chart easel

*page 11*



## Developing people and technology *continued from page 1*

lumber, and sawmills proliferated across the state. The result is that we now lag far behind our neighbors of Tennessee, Indiana, Virginia, and North Carolina in secondary wood processing, while we continue to ship millions of board feet of rough lumber annually to these and other states.

But opportunity is knocking for Kentucky's secondary wood products industry. As environmental concerns restrict the use of forests around the world, manufacturers and distributors are looking to our forests of yellow poplar, oak, and other hardwoods as an alternative source. Kentucky holds the opportunity to build the secondary wood industry to help supply the demand for hardwood products; but also faces the danger of missing the opportunity and watching rough lumber leave the state at an increasing rate.

But for Kentucky to rise to this opportunity, we must work to develop our workforce and our technology. We must be competitive in a global market. Export markets offer the best opportunity for expansion of value-added wood processing, and some Kentucky companies are already beginning to participate. In both foreign and domestic markets, Kentucky companies have short-term advantages in materials and labor, but to remain competitive will require improving both technological and human factors.

In regard to human factors, the greatest deficiency faced by the wood industry in Kentucky is the lack of adequately prepared workers, especially those at the level of supervision and management. There is currently less educational opportunity available for those seeking a career in the wood industry than ever before. Until the industry is strong enough to demand that programs be put in place, education will remain a hindrance to development.

The wood industry has traditionally been somewhat slow to adopt new technology, and Kentucky companies, being generally smaller than average, are in even worse position in that regard. Secondary wood processors from out of state will bring improved technology with them. However, for existing

companies to grow, a strong program of encouragement to modernize is needed.

Public policy will also affect the direction of wood industry development, both by legislation regarding education and technology and by regulations on forest use. Due to conservation policy, millions of acres of forest land have been removed from production of timber, leading to a steady decline in lumber production in other parts of the U.S.

When one source of supply is restricted, the natural response of the market is to seek a new

Kentucky holds the opportunity to . . . help supply the demand for hardwood **products**; but also faces the danger of missing the opportunity and watching **rough lumber** leave the state at an increasing rate.

source. For example, Appalachian yellow poplar is being used as a substitute for ponderosa pine, the prime western species for millwork and mouldings. Shifts like

this may account for significant growth for Kentucky over the next five to ten years. However, the overriding issue of preservation will eventually affect all forests.

The effects of regulation based on concern for the environment can include: 1) elimination of the forest from production, 2) restriction on the amount of timber harvested, or 3) restrictions on loggers and landowners regarding methods of harvesting timber. All of these will lead to decreased production and higher prices for wood products.

This behavior of the market is not appreciated by many who are concerned that our forests are going to be depleted. Some are convinced that we are in imminent danger of literally using up our forests. But what is more likely to happen is that as demand increases toward the point that the forests cannot supply enough timber, prices will increase as well, restricting the demand.

A more desirable scenario would be that before the critical point is reached, landowners, businesses, and public officials would recognize the problem and institute better forest management practices. But even in the absence of widespread forest management, the market will adjust, trees will continue to grow, and we will not run out of wood.



# Adding value piece by piece

*continued from page 1*

the future of the industry as a stable part of the state's economy.

In the past most timber companies have shipped green lumber out of West Virginia to furniture manufacturers in other states, but the rising costs of transporting materials is changing the way companies do business. Today companies are looking to eliminate waste by producing products closer to a sustainable source of raw materials. Sustainability is perhaps the most important factor in locating a manufacturing plant, as the investment is long-term.

Large companies might invest as much as \$125 to \$150 million in a factory, which is often financed for 30 years. In West Virginia, the companies can expect raw materials, other resources and the workforce to be there for the time it takes to pay back the investment and beyond. Because many of the large companies use smaller trees and the upper part of trees that are not traditionally used by sawmills, they are using a resource that ten or fifteen years ago was just left sitting in the woods.

But large companies aren't the only beneficiaries of the booming timber business in West Virginia. Owners of small, in-state sawmills are finding opportunities to expand and diversify their products from rough sawn lumber to dimensional wood products, which are pre-cut, pre-finished or semi-finished pieces that are sent to manufacturers to be assembled into completed furniture or other wood products.

Large furniture companies now focus on development and design, construction and marketing of their products. Much like automobile companies that use pre-fabricated parts to assemble a car, fewer finished wood products companies machine their own parts in-house. Instead, they order dimensional parts on a contractual basis, a practice that eliminates waste and cuts down on overhead.

This practice lends to a re-creation of cottage industries, creating opportunities for entrepreneurs to produce semi-finished and finished parts from small shops. Because these cottage industries often develop from existing small businesses, the economic growth is internal. With today's technology, even small producers can find international markets.

Of course, a growing industry and changing technology produces the need for constant re-education and training of the workforce. West Virginia has several resources dedicated to forestry and wood products, one of which is the Appalachian Hardwood Center at West Virginia University in Morgantown. The Hardwood Center offers technical assistance to companies in the state. In Princeton, the Robert C. Byrd Training Center provides technical training on running and maintaining various new machines and other woodworking technology.



## How to reach the resource organizations for our lead articles

Eastern Kentucky Technology Center  
Eastern Kentucky University  
307 Fitzpatrick Building  
Richmond, KY 40475-3115  
(606) 622-1187

Appalachian Hardwood Center  
Division of Forestry  
PO Box 6125  
West Virginia University  
Morgantown, WV 26506-6125  
(304) 293-7550

Clinch Powell Sustainable Development Initiative  
PO Box 791  
Abingdon, VA 24212-0791  
(540) 623-1121

## Updating old techniques *continued from page 1*

This good news, however, also gives rise to some bad news. The abundance of our forests is being used by regional state economic development officials to recruit huge chip mill factories and other wood-based manufacturers that may well lead to timber harvesting rates well beyond the forests' regenerative capacity. Many of these large facilities produce a lower value product such as chip board or trusses, which add relatively little value to the raw material. Finally, the current positive rate of regeneration is only statistical and may mask other problems, such as reduction of species diversity and a general decline in tree size, health and quality.

But there are ways to build a forest economy that creates a large number of locally based jobs, while helping to rejuvenate forest health and diversity. The Clinch Powell Sustainable Development Initiative is one effort underway to promote sustainable wood products industries. The Initiative's wood products strategy focuses on increasing employment while reducing stress on the forest ecosystem.

The Initiative is working to train loggers in environmentally sensitive harvesting practices. The training includes elements of forest ecology, directional felling, chain saw safety, and tree selection.

Particularly interesting is the training in utilizing horses as the primary power for skidding logs out of the forest. The updated version of this old-fashioned technique has reduced damage to the forest and risk to the logger and animals. While some established loggers choose to continue using machinery in an environmentally sensitive way, those who are just starting a business find the \$25,000 cost necessary to capitalize a horse logging business more feasible than the \$100,000 required for a conventional operation.

The Initiative works to promote maximizing the value of each log harvested by sawing, drying, and manufacturing it into finished products. When economists speak of adding value, they are referring to any process that takes a raw material closer to its

... there are ways to build a forest economy that creates a large number of locally based jobs, while helping to rejuvenate forest health and diversity.

jobs and generates revenue. In our current situation, most of this processing is done far from where the resource is located. Wood is shipped out as unprocessed logs, leaving little economic value in the region, and increasing the rates of timber cutting.

Wood manufacturing facilities are vital to adding value locally to wood products. In Tennessee, an entrepreneur who does environmentally sensitive logging has also built a wood manufacturing facility that focuses on making high value wood products from lower value species. The factory turns out

tongue and groove wall boards from poplar and beech, cabinets of sycamore, and book shelves using scrap oak.

The Clinch Powell Initiative is working to develop and apply certification standards to ensure sustainable forestry is employed. While only a

few sustainably harvested logs have been sold under the certification standards, a test marketing of certified lumber and wood products will begin soon.

The test marketing will include assessing markets within and beyond the Appalachian region. Three kinds of markets currently exist for sustainable wood products: sales of finished, dried lumber to manufacturers in the region; development of regional craft associations and manufacturers who use small quantities of diverse wood species; and exports of sustainable lumber to businesses which are promoting sustainably harvested wood products.

Maintaining healthy, diverse forests will require entrepreneurs skilled in environmentally sensitive techniques and an infrastructure that supports their efforts. The public will also play a role in supporting their efforts through our choices in the marketplace.

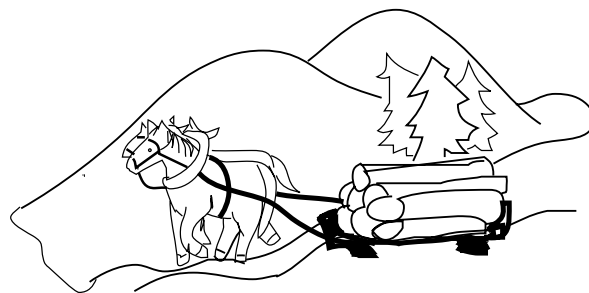

# Teamwork for Tomorrow

## Workshop dates set for spring of '97

Dates have been set for a third round of Teamwork for Tomorrow workshops. The workshops will be co-sponsored by the following eastern Kentucky area development districts: Gateway Area Development District, Buffalo Trace Area Development District, Cumberland Valley Area Development District, and Lake Cumberland Area Development District.

The one-day workshops will include sessions on strategic and tactical planning, fundraising and involving citizens in community efforts. The program will be open to community organizations and individuals from all eastern Kentucky counties.

In addition to the one-day workshops, the Institute will hold a two-day follow-up workshop at which participants will practice program planning and

proposal writing. The two-day workshop will take place March 14-15, 1997, on the Berea College campus.

Organizations that send three members to the one-day and two-day workshops and that meet other program criteria will be eligible to apply for mini-grants for community projects. During the last Teamwork for Tomorrow program over 45 organizations received organizational development training. A total of \$25,000 in mini-grants was distributed among seventeen organizations.

The Teamwork for Tomorrow Program is funded by the Appalachian Regional Commission through the Office of the Kentucky Governor. For more information, look for a forthcoming brochure or call Van Gravitt at Brushy Fork, (606) 986-9341, extension 6838.

The Teamwork for Tomorrow one-day workshop sessions will be held as follows:

1. Gateway ADD, February 11 at the MSU-Licking Valley Center in West Liberty.
2. Cumberland Valley ADD, February 12 at the ADD office in London.
3. Buffalo Trace ADD, February 19 at the City Hall Building in Vanceburg.
4. Lake Cumberland ADD, February 20 at ADD office in Russell Springs.

Registration deadline is January 30, 1997.

## Williams joins Brushy Fork staff

The staff of Brushy Fork would like to welcome and introduce Kathy Williams, who replaces Amy McCowan as administrative assistant for the Institute.

Kathy came on board in early September and brings several years of experience from the Service Learning Alliance, a placement organization for college students who volunteer their services to nonprofit organizations throughout the world.

In addition to working at Brushy Fork, Kathy is a part-time faculty member at Berea College, teaching first-year students in the General Studies Department. She also writes freelance for the local newspaper.

Amy McCowan served as administrative assistant for nearly two years. She left to join her husband Joe, who acquired a teaching position in Anderson County, Kentucky. We wish her well!

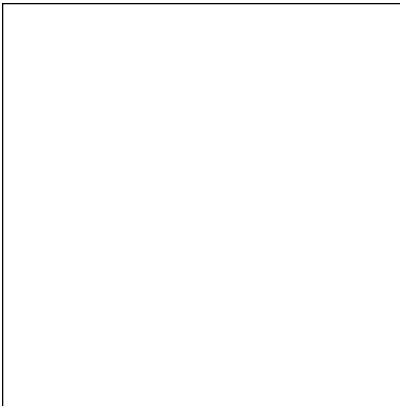

Kathy Williams serves as Brushy Fork's new administrative assistant

from the mailbox 

## Reader questions ginseng security

Dear Editor:

I read with interest the article, *Wild-simulated Ginseng: A sustainable agriculture alternative*, by David Cooke in the *Mountain Promise* (Vol. 6, No. 4, page 9). Unfortunately Mr. Cooke omitted the main reason ginseng is not more widely cultivated in West Virginia and the surrounding area—the challenge of keeping your ginseng crop secure.

Mr. Andy Hankins, a professor in alternative agriculture at Virginia State University, mentioned the topic at the Ginseng Conference held April 21, 1995, at Pipestem State Park. He said that the mind-set in our state is “if I find your ginseng patch, it’s mine, and I’ll dig it if I think I can get away with it.”

Mr. Hankins’ suggestions for security of your ginseng patch are to camp by the patch twenty-four hours a day until it is harvested or to grow it out of state on a friend’s property—both unworkable solutions.

Until the problem of security for a patch of ginseng is addressed rationally and a reasonable solution is found, Mr. Cooke’s old idea of growing a good cash crop is the waste of time it has always been in this area. Think about it for a minute. If it weren’t for this problem, everyone would be growing it right now.

Sorry, Mr. Cooke, good idea and one that’s been around for decades. Too bad you couldn’t solve the main problem that is preventing everyone and his uncle from setting out a patch of ginseng in West Virginia.

Sincerely Yours,

Robert L. Peck, Hinton, WV

Thank you for the letter, Mr. Peck. Does anyone have an answer about how to keep a ginseng crop secure? Please feel free to respond to Mr. Peck’s letter and we’ll try to print the answer in the spring issue of *Mountain Promise*.

—Donna Morgan, editor

## On the Leading Edge in West Virginia

The past several months have found Brushy Fork staff active in West Virginia, providing services to several organizations through the Leading Edge Program. One exciting project involved work with the Benedum Initiative. The Benedum Foundation started the program to encourage interdisciplinary activity among community groups in the state. Brushy Fork facilitated workshops and planning meetings and provided support for a two-day celebration in November.

Brushy Fork has also been working with the West Virginia Coalition on Food and Nutrition. The Coalition adopted Brushy Fork’s Leadership Development Program model for counties in which it works. Brushy Fork staff provided “trainer-training” for Coalition staff members.

Brushy Fork also has worked with the West Virginia Community Collaborative, a network of organizations that provide community development in the state. The organizations share session ideas and facilitation tips to increase the impact of their work.

## Spring *Mountain Promise* will focus on poverty and welfare reform in the region

*Mountain Promise*, the newsletter of the Brushy Fork Institute, is published quarterly. Our next issue will examine poverty and welfare reform in Appalachia. We encourage readers to submit articles, reports, photos, line art or story suggestions. If you have an article or a story idea, contact:

*Mountain Promise*, attention Donna Morgan  
Brushy Fork Institute  
CPO 35, Berea College  
Berea, KY 40404  
Phone: (606) 986-9341 extension 6838  
Fax: (606) 986-5510  
e-mail: Donna\_Morgan@berea.edu

We look forward to hearing from you!

## Forestry and wood products



Brushy Fork's resident surfer, Van Gravitt, perused the Internet for sources on forestry and secondary wood products. Below are some of the sites he found.

### AppalFor (Forestry issues)

<http://www.uky.edu/Agriculture/Forestry/AppalFor/high.html>

The goal of AppalFor is to collect, develop, discuss, and disseminate information on sustainable forestry on-line through the World Wide Web.

### Secondary Wood Products Consortium

<http://www.lbcc.cc.or.us/swpc/swpc.html>

The Secondary Wood Products Consortium home page contains links to training for the secondary wood products industry and other related sites,

created as a partnership between the industry and community colleges.

### Steve Shook's Directory of Forest Products, Wood Science, & Marketing

<http://www.weber.u.washington.edu/~esw/fpm.htm>

This is the most current and complete forest products directory on the Internet. The site contains over 1500 links to industry statistics, publications, marketing information, sustainability, and equipment. A few of the links available from this page are listed below.

### Some links from Shook's Directory

- **Academic and Other Research Institutions:** a link to university and government sites conducting theoretical and applied research in wood science and technology, forest products development and manufacturing, and forest products marketing and trade.
- **Internet Mailing Lists:** a description of several Internet e-mail lists and a step-by-step guide to signing onto them is provided on this page.
- **Manufacturers Equipment and Distributors:** a list of links to wood product and wood-related manufacturers, equipment manufacturers, retailers, wholesalers, and distributors.
- **Publications (On-line and Off-line):** links to sites that contain information on forest products, wood science, forestry, and construction related publications that are available both on-line and off-line (subscribe on-line).
- **Forest Products Certification and Sustainability:** find out what impact the certification and sustainability movement have had with respect to wood products and forestry.
- **Marketing Information Related To Forest Products:** links to sites dealing with the topic of marketing in general, as well as the marketing of forest products.

## States offer Master Logger Program

As the demand for Appalachia's hardwoods increases so may the call for regulations. The state Divisions of Forestry, in collaboration with other organizations, offer Master Logger Programs to help loggers prepare for regulations and learn responsible, sustainable forestry practices.

The program has received a warm welcome from loggers throughout the region. "Our classes are huge," noted Larry Lowe of the Kentucky Division of Forestry. "We have received a positive response from

loggers who may have approached the class with some trepidation."

For more information in Kentucky, call the Kentucky Forest Industries Association at (502) 875-3136 or the University of Kentucky Department of Forestry at (606) 257-5994. For information in Tennessee, call the Division of Forestry at (615) 360-0720 or the Extension Service at (423) 974-7346. For more in formation in Virginia and West Virginia, call the state Divisions of Forestry at the numbers listed on pages 9 and 16.

---

## *Some facts about our forests*

# State Divisions of Forestry provide some statistics

### **In Kentucky**

In 1986 Kentucky's growth to harvest ratio was 2.6 to 1. Has the ratio changed in the past ten years?

With half of the state in forest, Kentucky will play a major role in meeting the increased demand for hardwood that is affecting the entire South. So goes the prediction of Larry Lowe of the Kentucky Division of Forestry.

Ninety-three percent of the 12.7 million acres of Kentucky's forest land is privately owned, so many local residents may find themselves making wood industry-related decisions about how Kentucky's resources will be used. Hardwoods will be in greatest demand, as the need for materials to produce furniture, cabinets, flooring, pallets, housing materials and other products grows.

Over 90% of Kentucky's forests consist of hardwood trees that provide the basis for secondary wood industries. The woods in highest demand are prevalent in Kentucky: yellow poplar, white oak, black oak, northern red oak, chestnut oak, hard maple and ash.

The Kentucky Division of Forestry is currently working to update wood industry data that was last gathered in 1986. In the 1986 survey, the growth to harvest

ratio was 2.6 to 1. Lowe commented, "We don't know if the growth to harvest ratio is still at this rate. What we do know is that we have to maintain a 1:1 or higher ratio to insure the sustainability of Kentucky's forest resources." Because the harvest situation is changing so rapidly, the Division of Forestry plans to institute more frequent methods to track supply and demand.

The survey indicated that much of the wood was being used in-state. In 1986 Kentucky produced 824 million board feet of saw logs and consumed 807 million board feet. Of the 824 million board feet produced, 42 million board feet were exported. Of the 807 million board feet consumed, 25.5 million board feet were imported from other states.

Data from a 1995 survey of Kentucky forest industries will be available from the Division of Forestry in about six months. The survey will note which trees are being removed at what rate and will provide export and import information. For more information call the Kentucky Division of Forestry at (502) 564-4496.

### **In West Virginia**

In 1995, West Virginia's growth to harvest ratio was 1.3 to 1. Could the harvest rate actually be decreasing?

Nearly 4/5 of West Virginia is in forest, making trees an important resource for the state. The majority of West Virginia's trees are hardwoods, with a few red spruce and white pines. Private land owners hold 90% of these forests, so just as in Kentucky, local residents will be decision-makers regarding this resource.

According to a 1995 survey by the West Virginia Division of Forestry, the growth to harvest ratio for trees was 1.3 to

1. The state had a standing inventory of 70 billion board feet of lumber. About 800 million board feet were being sawed each year, with 733 million board feet being used in-state mainly for pallet, flooring, casket and cabinet production. Ed Murriner of the West Virginia Division of Forestry pointed out that some of the wood being used in-state was actually imported from other states, so West Virginia does export some of its lumber.

---

## about the states' forests

Much of West Virginia's higher grade lumber is exported to furniture factories in Virginia, North Carolina and Ohio. Other high grade hardwoods are exported overseas as veneer.

Murriner also noted a new market for tree tops that were formerly left in the woods after logging was finished. West Virginia has two factories that process

these soft hardwoods into oriented strand board or OSB. Strips from the tree tops are compressed into panels that can be used like boards.

The West Virginia Division of Forestry is currently working on a written report from the 1995 survey. For more information, contact the Division of Forestry at (304) 558-2788.

Private ownership of forest land in Tennessee is shifting from farmers to absentee landowners, who now hold 41% of privately owned forests.

## In Tennessee

Did the state of Tennessee have more forest land in 1920 or in 1989? Today, half of the state of Tennessee is in forest. That's 13.6 million acres, 4.3 million more acres than the state had in 1920.

But according to the Tennessee Division of Forestry, more trees doesn't necessarily mean better trees. A 1989 survey noted the growth to harvest ratio for trees as 3 to 1, but while the volume and age of trees being left is increasing, the quality is decreasing. State wide, Tennessee is growing more timber than is being harvested, although some local areas may be experiencing more harvest than growth.

Private landowners hold over 86% of the forest land in the state. Data from the 1989 survey showed a shift of this private ownership from farmers, who held a little over 28% of the land, to absentee landowners, who held 41% of the land.

Hardwoods make up 89% of Tennessee's forests. These trees, along with softwoods, are used for paper, lumber and furniture. The wood products industry employs 44,212 people and pays wages of over 800 million dollars per year.

According to the 1989 survey, Tennessee removed 829 million board feet of saw timber from its forests. Forestry official David Arnold says its unclear how

much of this wood was used in-state and how much was exported. Interstate travel of wood can be difficult to track. Arnold explains, "Sawmills that are located just across the border in Kentucky or Georgia may process logs cut from Tennessee's forests, which are then shipped to Indiana as veneer that in turn is shipped to Germany."

Asked what the future holds for Tennessee's forests, Arnold responds, "That depends on how conscientious landowners are at practicing true forestry and good forest management." Some current practices such as high grading (removing all the best trees and leaving behind lower quality timber) have left many forested areas in Tennessee stocked with low quality trees.

As landowners are encouraged to apply proven silvicultural systems to their land, Tennessee's forests should grow better quality trees and more volumes of timber. Also, timely implementation of forestry practices will go a long way to correct any harvest to growth imbalances that might be occurring at local levels.

For more information contact the Tennessee Division of Forestry at (615) 360-0720.

*continued on page 16*

## Local woodcrafting in Southwestern Virginia

by Phyllis Deel, Dickenson County Extension Agent and Brushy Fork Associate

In the early 1900's, Southwestern Virginia was one of the largest timber suppliers in the world. Later this century, many families became dependent on coal mining for their income. Now that the coal has run out, wood products are once again providing a source of income. But this time rather than shipping out rough lumber, skilled woodcrafters are producing fine secondary wood products for the regional market. Several programs have been implemented to promote these home-based businesses.

The Virginia Cooperative Extension Specialists sponsored "Integrating Home-based Business and Alternative Agriculture Into Southwest Virginia" to help people develop or improve home-based businesses. A large segment of the participants were crafters who needed assistance with marketing. Workshops were held to teach participants to identify and refine their products and services and to develop pricing and promotional techniques.

Seminars like these led to the development of marketing tools such as *The Marketing Directory for Southwestern Virginia Artisans*, a publication of fairs and festivals within a two hundred mile radius of Southwest Virginia. The publication, which is being geared up for its fourth year, also lists shops that either buy or consign arts and crafts items.

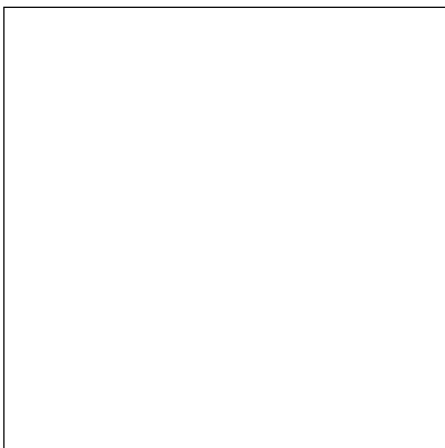

photo by Phyllis Deel

Deloras Moore looks forward to using environmentally sensitive logged lumber to produce her crafts.

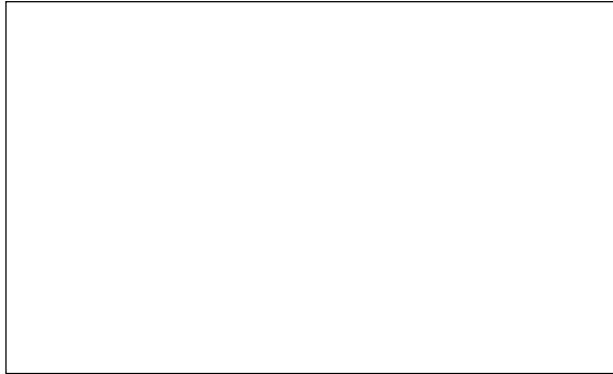

photo by Phyllis Deel

Jim Hearl of Dickenson County, Virginia, uses his "one-man" sawmill to process locally harvested hardwoods for products ranging from furniture to finely finished boxes, clocks, bowls and jewelry.

The educational project has also helped prepare for other programs such as the Purely Appalachia Crafts Empowerment Program (PACE). PACE is conducted by the Coalfield Tourism Development Authority for Dickenson, Wise, Scott, Lee, Russell, Tazewell, and Buchanan Counties and the city of Norton.

PACE identifies crafters who have products that can be produced in volume and priced wholesale. PACE serves as the "middle man," supplying area tourism attraction shops with local products. Both producers and retailers benefit from this approach—the crafters don't have to spend time marketing their products, and the shop owners don't have to deal with multitudes of crafters. PACE is looking at opportunities to move products out of the local area.

So, what kinds of artisans are programs like PACE working with?

Glen Nickels of Scott County, is a PACE participant. Mr. Nickels "reclaims" trees or parts of trees with unusual wood types and grains. He takes advantage of special features that add uniqueness to his vases, candlesticks and other items. Mr. Nickels also "reclaims" aged fence posts and other items that would otherwise go to waste.

Another Purely Appalachia woodcrafter is Deloras Moore, a woman in a predominately male craft area. Deloras crafts a wide variety of items ranging from rocking horses to home accessories. She is looking forward to using environmentally sensitive logged lumber, an aspect of her product that will serve as a marketing tool. By using their own talent and creativity, she and other Southwest Virginia artisans are finding ways to use local resources in a responsible way.



## On constructing a folding flip chart easel

Brushy Fork's own contribution to the secondary wood industry is a plan for a folding wooden flip chart easel. To make your own easel, follow these instructions:

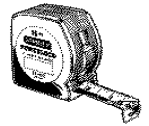

- 1) All parts in the prototype are 2" x 13/16" poplar. Hardwood is recommended. 2" x 3/4" pine could be used, but should be clear of knots to assure strength.
- 2) All fixed parts are screwed together with 1 1/2" wood screws. For ease of construction, self tapping screws (such as drywall screws) may be driven in with a drill or power screwdriver.
- 3) Two additional screws are set in the top crosspiece to hang the flip chart pad on.
- 4) The folding legs are attached with 2" carriage bolts and wingnuts. The lower set of bolts are removed to fold the easel, and reinserted in the uppermost holes to hold the legs in the closed position.
- 5) The pivot bolt at the top should be 4" long, with washers on each side, and fastened with two nuts to prevent loosening. The bolt should not be so tight as to cause the back leg to bind excessively. Note that the holes in the side legs must be drilled at an angle to allow insertion of the bolt. This may be accomplished by assembling the lower crosspiece to the A-frame, then holding the tops of all three legs in alignment and drilling them all at once.
- 6) Short lengths of chain and screweyes may be used to connect the back leg to the front legs.
- 7) (Optional) A piece of plywood or masonite may be added to the easel if desired to allow the use of single sheets of paper instead of flip chart pads.

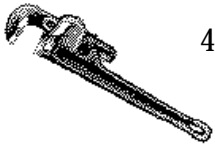

### Wood parts:

Number	Size	Description
3	44" x 2" x 3/4"	Upper leg sections
3	34" x 2" x 3/4"	Folding (lower) leg sections
3	27" x 2" x 3/4"	Cross pieces (upper, lower, and pencil ledge)

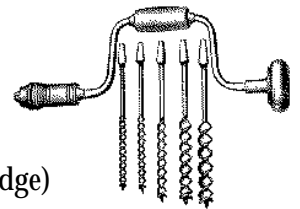

### Hardware:

- 10 1 1/2" Wood screws
- 6 2" Carriage bolts with wingnuts
- 1 4" bolt with 2 washers and two nuts
- 3 screw-eyes
- Approximately 4' of lightweight chain

*See the back of this page for a plan for the folding flip chart easel.*

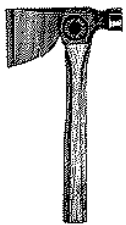

# Brushy Fork Folding Flip Chart Easel Plan

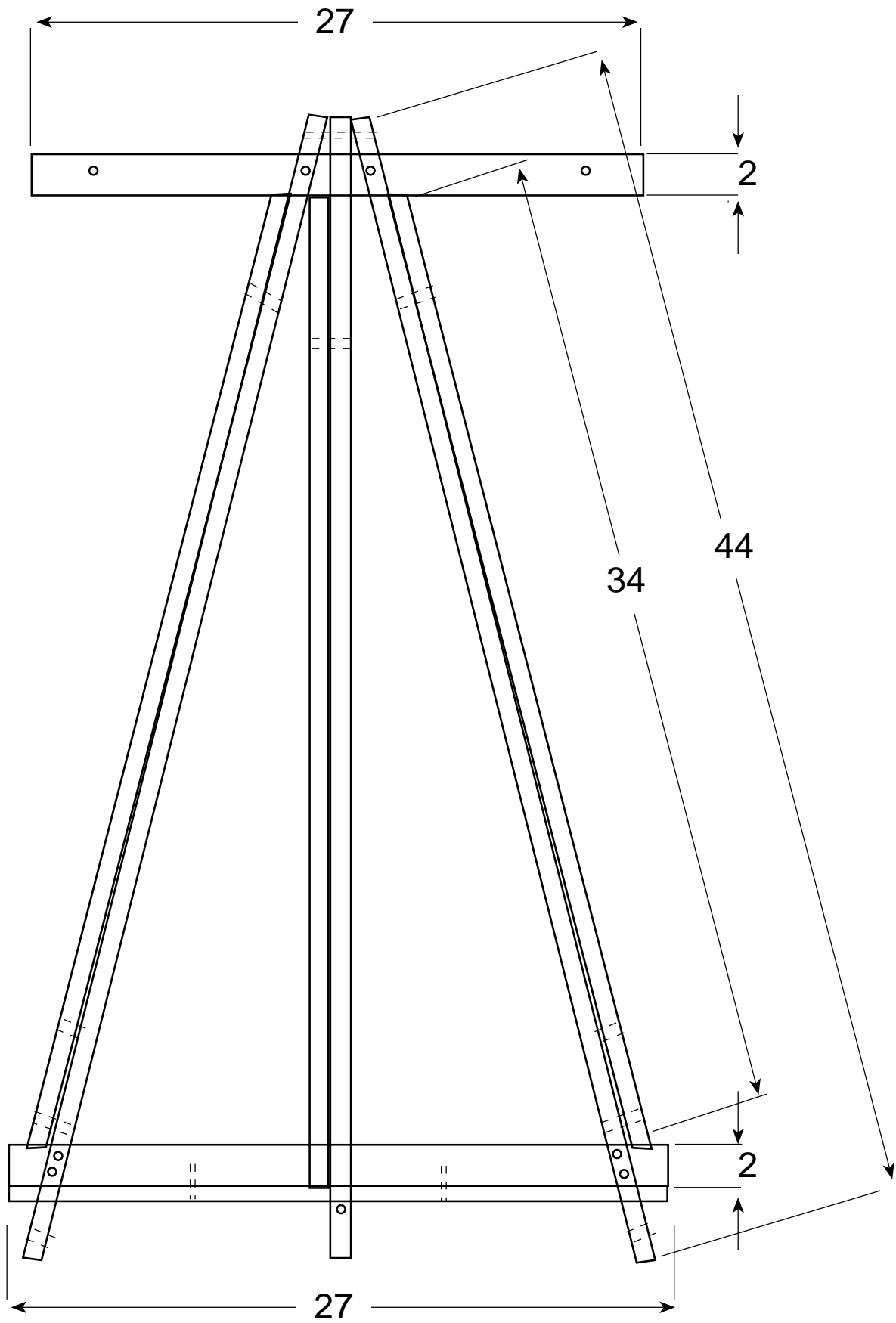

'96 additions!

## Additions to Directory of Brushy Fork Associates

Four new teams started the Brushy Fork Leadership Development Program in 1996. This page can be clipped and added as an update to your Directory of Associates.

### Bell County, Kentucky

#### Project: Initiate a county-wide fair

<i>Name</i>	<i>Address</i>	<i>City</i>	<i>State Zip</i>	<i>Home phone: work phone</i>
Armitage, Robin	202 Park Avenue	Pineville,	KY 40977	606 337-6874; 606 337-7051
Brown, Michelle	PO Box 788	Middlesboro,	KY 40965	606 242-3710; 606 248-1075
Coleman, Sam	203 Rochester Avenue	Middlesboro,	KY 40965	606 248-1899
Crawford, Tim	PO Box 135	Frakes,	KY 40940	606 337-1742; 606 337-3613
Hubbard, Latha	RT 2, Box 22	Pineville,	KY 40977	606 337-6911; 606 337-1515
Johnson, Romell	PO Box 1557	Middlesboro,	KY 40965	606 248-0043; 606 248-8001
Melton, Jim	160 Wellington Drive	Middlesboro,	KY 40965	606 248-6595; 606 248-6600
Mills, Jim	PO Box 199, HWY 66	Arjay,	KY 40902	606 337-7796
Money, Chad P.	1010 Exeter Avenue	Middlesboro,	KY 40965	606 248-0406
Quince, Aubrey	730 Winchester Avenue	Middlesboro,	KY 40965	606 242-3499; 606 248-0409
Roe, Louis	PO Box 2031	Middlesboro,	KY 40965	606 248-7986; 606 242-1101
Shattuck, Tom	224 Greenwood Road	Middlesboro,	KY 40965	606 248-2626

cut along dotted line



### Braxton County, West Virginia

#### Project: Install a walking trail/cross country track at the high school

<i>Name</i>	<i>Address</i>	<i>City</i>	<i>State Zip</i>	<i>Home phone: work phone</i>
Atkins, Tony E.	5317 Shadowbrook Road	Crosslanes,	WV 25313	304 776-8592; 304 364-5156
Boeger, Dick	197 Laurel Heights	Sutton,	WV 26601	304 765-3120
Canter, Florence	RT 1, Box 40	Walkersville,	WV 26447	304 452-8862
Cogar, Lela Joan	219 River Street	Gassaway,	WV 26624	304 364-5448; 304 765-2250
England, Amanda	PO Box 5	Sutton	WV 26601	304 364-8910
Friend, Melanie	HC 63, Box 16	Exchange,	WV 26619	304 765-2224
Fussell, Patty	PO Box 311	Frametown,	WV 26623	304 364-8646
Howard, Sally	101 Pinehurst	Sutton,	WV 26601	304 765-7533; 304 765-2809
Hyre, Shirley	Progress Route, Box 34	Gassaway,	WV 26624	304 354-8424; 304 364-5105
Jack, Dave	HC 36, Box 75	Exchange,	WV 26619	304 765-5956; 304 853-2605
Mazon, Lou Ann	1408 Chapel Road	Gassaway,	WV 26624	304 364-5027; 304 364-8976
Napier, Rita	RT 1, Box 27	Frametown,	WV 26623	304 364-8543; 304 364-5526
Sowa, Cathy	HC 69, RT2, Box 11A	Frametown,	WV 26623	304 364-8139

## Directory additions, continued

### Smith County, Tennessee

**Project: Install new playground equipment at local park/feasibility study for community center**

<i>Name</i>	<i>Address</i>	<i>City</i>	<i>State Zip</i>	<i>Home phone: work phone</i>
Bush, Pat	10 Mulberry Lane	Carthage,	TN 37030	615 774-3283; 615 735-1326
Cannon, Rachel	6 T&P Lane	Carthage	TN 37030	615 735-1865
Carr, David	112 Swanee Lane, #9	Carthage,	TN 37030	615 735-3659;615 683-8245
Clay, Cara	PO Box 57	Hickman,	TN 38567	614 683-6154
Dendler, Rich	315 Hull	Carthage,	TN 37030	615 735-2032
Dillehay, Geneil	88 Difficult Road	Carthage,	TN 37030	615 774-3633; 615 774-3633
Habersberger, Don	303 Valley View Drive	Carthage,	TN 37030	615 735-0197; 615 683-6411
Lee, Linda	59 Bear Wallow Gap Road	Carthage,	TN 37030	615 774-3274; 615 736-5635
Lynch, Janice	7 Kent Lane	Gordonsville,	TN 38563	615 683-8599
Martin, April	PO Box 121	Carthage,	TN 37030	615 683-6954; 615 735-2900
Pedigo, Janie	409 Kenway Street	Cookeville,	TN 38501	615 528-9022; 615 735-2900
Price, Wilma	10 Bob Williams Lane	Pleasant Shade,	TN 37145	615 677-6629; 615 735-0333
Reid, Sam	10 Bob Williams Lane	Pleasant Shade,	TN 37145	615 735-2930; 615 677-6629
Taylor, Kristy	299 Sykes Road	Brush Creek,	TN 38547	615 286-4032; 615 735-9202
Thompson, Mabel	223 Jackson Avenue	Carthage,	TN 37030	615 735-2382
Young, Faith	1004 Dixon Springs Hwy.	Dixon Springs,	TN 37057	615 735-1862

### Smyth County, Virginia

**Project: Establish a youth advisory board to get a teen center up and running**

<i>Name</i>	<i>Address</i>	<i>City</i>	<i>State Zip</i>	<i>Home phone: work phone</i>
Devlin, Bob	RR 3, Box 268	Saltville,	VA 24370	540 624-3872; 540 783-6441
Heath, Ken	317 Worley Street	Chilhowie,	VA 24319	540 646-2526; 540 783-4113
Maiden, Adam	PO Box 689	Saltville,	VA 24370	540 496-5407
Maxey, Ronald	425 Douglas St., B-5	Marion,	VA 24354	540 783-4131
Saufley, Richard	RT 2, Box 196	Marion,	VA 24354	540 783-7993; 540 783-2397
Trivette, Drew	HC 61, Box 39	Chilhowie,	VA 24319	540 646-3881
Vernon, Teena	PO Box 374	Marion,	VA 24354	540 783-1779; 540 783-5524
Wilson, Judy	PO Box 510	Marion,	VA 24354	540 429-2893; 540 783-5175
Wood, Bently	RT 2, Box 516	Chilhowie,	VA 24319	540 646-2210; 540 783-3178

## *Bringing Home Team Leadership and Community Projects*

# 1996 Leadership Development Program underway

On September 26 four new county teams made the trek to Berea College for the opening workshop of the Brushy Fork Leadership Development Program.

Community leaders from Bell County, Kentucky; Smith County, Tennessee; Smyth County, Virginia; and Braxton County, West Virginia, gathered to discuss leadership, practice new skills and look to the future of their home communities. The teams left Berea with plans laid, timelines set and goals established for each of their projects.

### **Bell County, Kentucky**

The group from Bell County, Kentucky, elected to initiate a county fair. Although Bell County is home to several festivals, each event is associated with a particular community. The Bell County team, Bell Leaders Achieving a Stronger Tomorrow (BLAST), felt that a county-wide fair would help unify the small communities that are separated by geographical and social divisions.

By the end of the six-month period BLAST aims to have chosen a date and location for the fair and have scheduled a series of events.

### **Smith County, Tennessee**

The team from Smith County, Tennessee, selected the name Visions in Progress (VIP) and chose to address the problem with lack of recreational facilities in their county. VIP's vision was for a community center with organized recreation for their county residents. Realizing that this project was well beyond the scope of six months, the group decided to start with a smaller recreation project.

VIP plans to install playground equipment for children at a local park, which currently has only a ballfield. As another step toward the larger vision, the team plans to conduct a needs assessment survey for a county recreation civic complex and, should enough interest arise, the group will support the long-term development of the complex.

### **Smyth County, Virginia**

Lack of recreational facilities also posed a problem for the team from Smyth County, Virginia. The Smyth County Action Team (SCAT) saw this shortfall as detracting from the overall quality of life in their communities, particularly for young people. To address this problem, the group chose to establish an advisory board of local high school students and open youth center in the county seat.

During the workshop team members made a call home and secured a pledge of a building site, an old bowling alley in downtown Marion. With plenty of youth input, the team plans to install a dance floor, a snack bar, and an arcade room to provide entertainment for youth.

To raise some money for the project, SCAT will lease booths at the center to vendors who want to market their products directly to teens.

### **Braxton County, West Virginia**

The team from Braxton County, West Virginia, undertook a project that would serve a wide range of people in their community.

After much deliberation, the Braxton Leadership Team (BLT) chose to build a quarter-mile circular track. They hope to connect this track to a nature trail at the local middle school/high school complex. The nature trail would provide a cross country track for students. The track would also provide wellness opportunities for all residents of the county.

### *in memoriam*

#### **Otto Fields and Carol Fouts**

During 1996 Brushy Fork learned of the passing of two Associates. Otto Fields of Jackson County, Kentucky, passed away following a battle with cancer. We also recently learned that Carol Fouts of Lee County, Virginia, has passed away.

Both Otto and Carol participated in the pilot cycle of the Brushy Fork Leadership Program.

Our condolences go to their friends and loved ones. Other Associates may want to note these passings in your Associate Directories.

# Forestry statistics

*continued from page 9*

## In Virginia

The state of Virginia is one of the largest producers of wood furniture in the United States, with the furniture industry accounting for 50% of value added to wood materials.

Over the past 50 years the inventory volume of wood in the Virginia's forest has increased by 81 percent. Today, 15.4 million acres, which is well over half of the state, are covered in forest. Private owners hold 77% of this land.

As in the other three central Appalachian states, hardwoods make up the majority of the total acreage of Appalachian Virginia's forests. These trees, along with several species of softwoods, are used for products ranging from rough lumber to paper to fine furniture. The wood products industry contributes \$9.8 billion to the economy of the state and employs 228,370 people. Virginia is one of the largest producers of wood furniture in the United States. The furniture industry accounts for 50 percent of the total secondary value added to wood materials.

When compared to other agricultural products, timber made up 16.7% of total agricultural values, ranking second behind poultry and eggs. Wood exports are becoming an increasingly important segment of this value. From 1989 to 1992 wood product exports increased from \$386 million to \$626 million.

When asked to address the issue of growth to removal ratios, Michael Foreman of the Virginia Department of Forestry noted that, due to recent increases in harvesting, any data more than three years old is inaccurate. The Division of Forestry is currently drafting a forest resources report that will examine population and land use data.

For more information contact the Division of Forestry at (804) 977-6555.

---

## *for the calendar*

---

### **Appalachian Studies Conference**

**March 14-16, 1997**

With the theme "Places Where the Mountains Have Gone," the 20th annual Appalachian Studies Conference will explore Appalachian migration to urban areas. The conference will be held at Drawbridge Estates in Fort Mitchell, KY. Contact the Appalachian Studies Association, PO Box 6825, West Virginia University, Morgantown, WV 26506.

### **Appalachian Summer Institute**

**June 16-July 3, 1997**

The 25th Berea College Appalachian Center Summer Institute will focus on Appalachian history and culture with the primary aim of helping teachers create courses in Appalachian studies. For more information, contact the Berea College Appalachian Center, CPO 2336, Berea, KY 40404; (606) 986-9341, extension 5140.

---

### **Brushy Fork Institute**

**Berea College CPO 35**

**Berea, KY 40404**

**606 986-9341 ext. 6838**

**NonprofitOrg.**

**ThirdClass**

**U.S. Postage**

**PAID**

**Berea, KY 40403**

**Permit #19**



Printed on recycled paper